

KENWOOD

PEAK POWER
PUISSANCE DE CRÊTE ADMISSIBLE
450W



Flush Mount Speaker

HAUT-PARLEUR ENCASTRABLE
ALTAVOZ DE MONTAJE A NIVEL
ALTIFALANTE DE MONTAGEM NIVELADA

KFC-6984PS

153x229mm
6x9in

4way
SPEAKER

110W
RMS POWER



PERFORMANCE SERIES

KENWOOD

PEAK POWER
450W



1 pair

Flush Mount Speaker

HAUT-PARLEUR ENCASTRABLE
ALTAVOZ DE MONTAJE A NIVEL
ALTIFALANTE DE MONTAGEM NIVELADA

KFC-6984PS

153x229mm
6x9in

4way
SPEAKER

110W
RMS POWER



SPECIFICATIONS

- Speakers
 - Woofer.....153 x 229 mm [6 x 9 in.] Cone
 - Midrange.....70 mm [2-3/4 in.] Cone
 - Tweeter.....20 mm [13/16 in.]
Balanced Dome
 - Super Tweeter.....20 mm [13/16 in.] Dome

- 110 Watts RMS
- Impedance.....4 Ω
- Sensitivity.....89 dB / W at 1 m
- Frequency Response.....63 Hz - 18,000 Hz
- Cutout Diameter.....5-7/8 x 8-9/16 in. Oval
(14.9 x 21.8 cm Oval)
- Mounting Depth.....3-1/16 in. (7.8 cm)



PERFORMANCE SERIES



TEMPLATE GABARIT PLANTILLA GABARITO

FLUSH MOUNT SPEAKER
HAUT-PARLEUR ENCASTRABLE
KFC-6984PS
INSTALLATION INSTRUCTIONS
PROCEDURES D'INSTALLATION

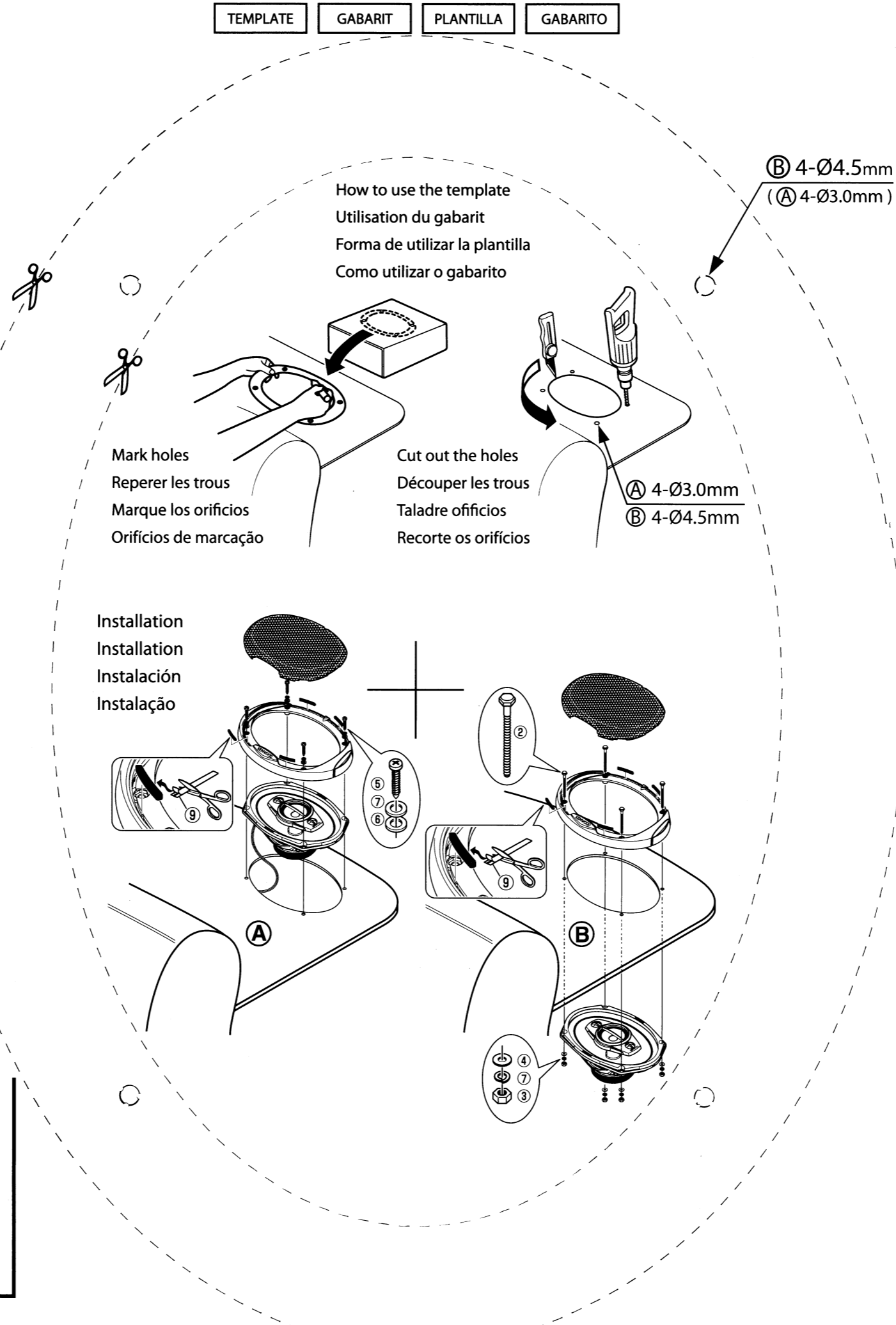

How to use the template
 Utilisation du gabarit
 Forma de utilizar la plantilla
 Como utilizar o gabarito

Mark holes
 Reperer les trous
 Marque los orificios
 Orifícios de marcação

Cut out the holes
 Découper les trous
 Taladre ofícios
 Recorte os orifícios

Installation
 Installation
 Instalación
 Instalação

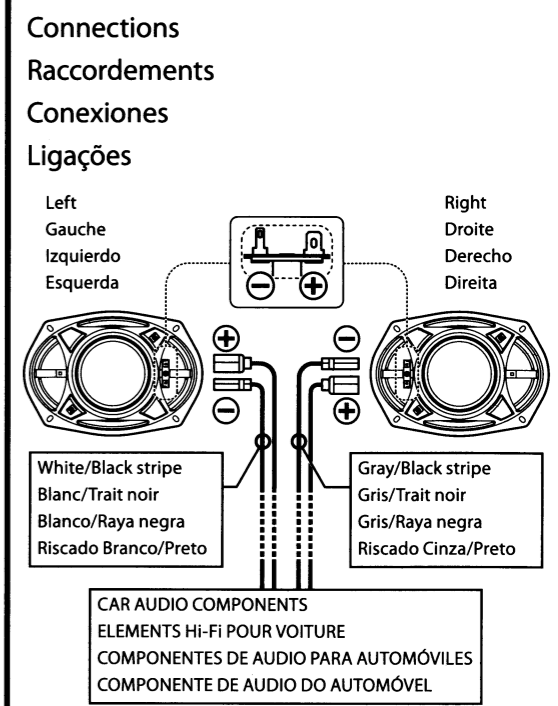
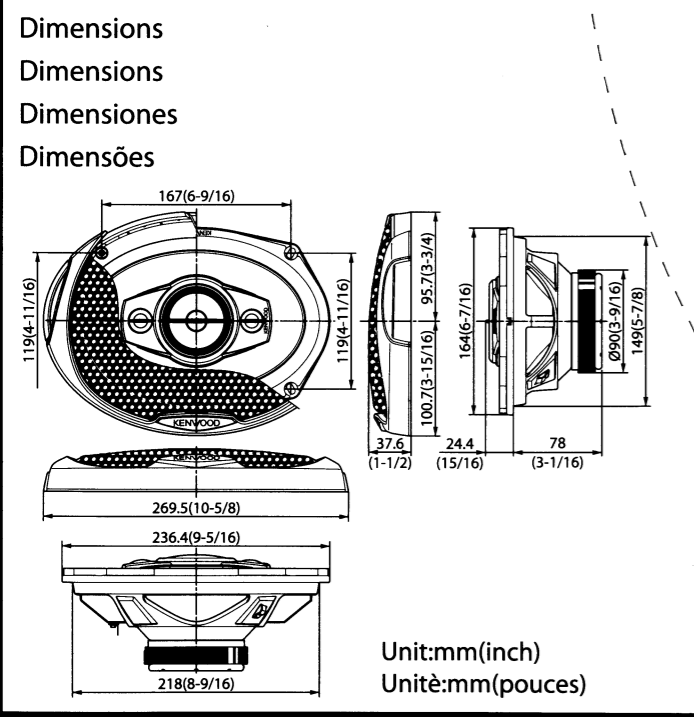

Parts included
 Pieces comprises
 Partes incluidas
 Peças inclusas

- ①x2
- ② M4x70.....x8
- ③ M4.....x8
- ④ M4.....x8
- ⑤ Ø4x40.....x8
- ⑥ Ø4.....x8
- ⑦ Ø4.....x8
- ⑧ 4.5m(15ft).....x2
- ⑨x2

■ Do not use the provided speaker cords for other purposes (such as a power cord). Otherwise malfunction or fire hazard could result.

■ Ne pas utiliser les cordons de liaison aux enceintes pour une destination autre que celle prévue (par exemple, pour alimenter un appareil). Faute de quoi, un défaut de fonctionnement ou un incendie pourraient en résulter.

■ No utilize los cables de altavoces suministrados para otros propósitos (tales como los de un cable de alimentación). Si no, podrían producirse averías o peligros de incendio.

■ Não utilize os fios fornecidos para altifalantes para outros propósitos (p.ex. como cabo de alimentação). Caso contrário, poderá resultar em mau funcionamento ou risco de incêndio.

JVC KENWOOD Corporation Kanagawa 221-0022 Japan

Designed and Engineered in Japan / Design et Conception au Japon
 Made in China / Fabriqué en Chine

VOLUME 0.0158 m³ / 0.56 ft³
 WEIGHT / POIDS 3.7 kg / 8.2 lb

IMPORTANT SAFETY INSTRUCTIONS



To avoid the risk of human injury or property damage, be sure to read and observe the following safety cautions.

Have a specialist install and connect the speaker. — Incorrect installation may lead to vehicle accident or malfunction.

Avoid unstable installation. — Make sure that the speaker will not rattle or displace. Otherwise, a displaced speaker may cause injury.

Do not modify the speaker. — Otherwise, smoke or fire may result.

Do not touch the speaker. — The speaker becomes hot after extended operation. Touching it in such a condition may cause burns.

Control listening volume at an optimum level. — If the sound outside the vehicle is inaudible, a traffic accident may result.

In case of abnormality, stop the use and disconnect the speaker. — If operation is continued, smoke or fire may result. Disconnect the speaker and ask servicing.

U.S.A. KENWOOD USA CORPORATION

This warranty will be honored only in the U.S.A.

KENWOOD LIMITED WARRANTY FOR CAR STEREO COMPONENTS

HOW LONG IS THE WARRANTY
Kenwood U.S.A. Corporation ("Kenwood") warrants this product for a period of one (1) year from the date of original purchase.

WHAT IS COVERED AND WHAT IS NOT COVERED
Except as specified below, this warranty covers all defects in material and workmanship in Kenwood car stereo components. The following are not covered by the warranty:

- Any product which is not distributed in the U.S.A. by Kenwood or which is not purchased in the U.S.A. from an authorized Kenwood car stereo dealer or an automobile dealer, unless the product is purchased through the U.S.A. Military Exchange Service.
- Any product on which the serial number has been defaced, modified or removed.
- Damage, deterioration or malfunction resulting from:
 - Any shipment of the product (claims must be presented to the carrier).
 - Installation or removal of the product.
 - Accident, acts of nature, misuse, abuse, neglect, unauthorized product modification or failure to follow instructions supplied with the product.
 - Repair or attempted repair by anyone not authorized by Kenwood.
 - Any other cause which does not relate to a product defect.

WHO IS PROTECTED
This warranty is enforceable only by the original purchaser.

WHAT WE WILL PAY FOR
We will pay for all labor and material expenses for covered items. Payment of shipping charges is discussed in the next section of this warranty.

HOW TO OBTAIN WARRANTY SERVICE
If your KENWOOD product ever needs service:

- Take or ship it to any KENWOOD Authorized Service Center in the U.S.A. along with a complete description of the problem. (If you are uncertain as to whether a Service Center is authorized, please call 1-800-KENWOOD for the nearest Service Center. 1-800-536-9663).
- Although you must pay any shipping charges if it is necessary to ship the product for warranty service, we will pay the return shipping charges if the repairs are covered by the warranty within the United States.
- Whenever your units are taken or sent for warranty service, you must include a copy of the original dated sales receipt as proof of warranty coverage.

LIMITATION OF IMPLIED WARRANTIES
ALL IMPLIED WARRANTIES, INCLUDING WARRANTIES OF MERCHANTABILITY AND FITNESS FOR A PARTICULAR PURPOSE, ARE LIMITED IN DURATION TO THE LENGTH OF THIS WARRANTY.

EXCLUSION OF DAMAGES
KENWOOD'S LIABILITY FOR ANY DEFECTIVE PRODUCT IS LIMITED TO THE REPAIR OR REPLACEMENT OF THE PRODUCT AT OUR OPTION. KENWOOD SHALL NOT BE LIABLE FOR:

- INSTALLATION OR REMOVAL CHARGES, DAMAGE TO OTHER PROPERTY CAUSED BY ANY DEFECTS IN KENWOOD CAR STEREO COMPONENTS, DAMAGES BASED UPON INCONVENIENCE, LOSS OF USE OF THE PRODUCT, OR
- ANY OTHER DAMAGES, WHETHER INCIDENTAL, CONSEQUENTIAL OR OTHERWISE.

SOME STATES DO NOT ALLOW LIMITATIONS ON HOW LONG AN IMPLIED WARRANTY LASTS AND/OR DO NOT ALLOW THE EXCLUSION OR LIMITATION OF INCIDENTAL OR CONSEQUENTIAL DAMAGES, SO THE ABOVE LIMITATIONS AND EXCLUSIONS MAY NOT APPLY TO YOU.

This warranty gives you specific legal rights, and you may also have other rights which vary from state to state.

If a problem develops during or after the Limited Warranty Period, or if you have any questions regarding the operation of the product, you should contact your KENWOOD Authorized Dealer or Authorized Service Center. If the problem or your question is not handled to your satisfaction, please contact our Customer Relations Department at the address listed below:

KENWOOD USA CORPORATION
P.O. Box 22745, 2201 East Dominguez Street, Long Beach, CA 90801-5745
Tel: (310) 639-5300

ATTENTION
This card and receipt (or invoice) are necessary to purchase a new panel in case of theft or damage.

MILITARY

Units purchased through the U.S.A. military exchange service overseas may be serviced under warranty in the continental U.S.A., subject to the following conditions.

- The original warranty is in effect.
- Proof of purchase is provided to the servicior.

WARRANTY FOR MILITARY MARKET

Kenwood corporation is proud of the quality and workmanship of its audio equipment. This unit has been properly designed, tested and inspected before it was shipped to you. If properly installed and operated in accordance with instructions furnished, it should give you an optimum reliable performance.

WARRANTY PERIOD
This product is warranted for a period of (1) year from the date of the original purchase.

SCOPE OF WARRANTY
Except as specified below, this warranty covers all defects in materials and workmanship of the Kenwood brand products.

During the warranty period, any authorized Kenwood Service Center in the military market listed in the back of this warranty card will provide you free-of-charge both parts and labor required to correct any defect in materials or workmanship.

The following are not covered by this warranty.

- Voltage conversions.
- Periodic check-ups which do not disclose any defect covered by the warranty.
- Cabinets, grilles, other exterior finishes, belts, tape heads, and other non-durable parts and accessories.
- Units on which the serial number has been effaced, modified or removed.
- Installation and/or removal charges.
- Damaged magnetic tapes.
- House call charges or any repairs.
- Shipping or delivery charges to or from an authorized Kenwood Service Center.
- This warranty will not cover any failure that is due to any of the following conditions in accordance with the visual inspection of the authorized Kenwood Service Center:
 - Improper maintenance or repair, including the installation of parts or accessories that do not conform to the quality and specifications of the original parts.
 - Misuse, abuse, neglect, unauthorized product modification or failure to follow instructions contained in the Owner's Manual.
 - Accidental or intentional damages.
 - Repairs or attempted repairs by an unauthorized agency. (All repairs must be performed at an authorized Kenwood Service Center.)
 - Damages or deteriorations caused during shipment (Claims must be presented to the carrier).
 - Damages or deteriorations resulting from removal and/or replacement.

PURCHASER'S RESPONSIBILITIES
As the purchaser of a new Kenwood brand product, you are requested to do the following in order to obtain Kenwood warranty service.

- Retain your sales slip or other evidence of purchase for proving your eligibility for requesting Kenwood warranty service.
- Make your unit available to an authorized Kenwood Service Center in the military market for inspection and approved warranty service, or ship your unit in its original carton box or equivalent, fully insured and shipping charges prepaid, to the authorized Kenwood Service Center.

LIMITATION OF IMPLIED WARRANTIES
Any and all implied warranties, including warranties of merchantability and fitness for a particular purpose, shall be limited in duration to the length of this warranty.

EXCLUSION OF CERTAIN DAMAGES
KENWOOD'S liability for any defective product is limited to the repair or replacement of said product, at our option, and shall not include damages of any kind, whether incidental, consequential or otherwise, except to the extent prohibited by applicable law.

ATTENTION
This card and receipt (or invoice) are necessary to purchase a new panel in case of theft or damage.

KENWOOD AUTHORIZED SERVICE CENTERS IN MILITARY MARKET

JAPAN:

Yokota
Kenwood Rep.; c/o
Yokota BX, JAAX AAFES-PAC,
APO San Francisco 96328

Zama
Kenwood Rep.; c/o
Zama PX, JAAX AAFES-PAC,
APO San Francisco 96343

Misawa
Kenwood Rep.; c/o
Misawa BX, JAAX AAFES-PAC,
APO San Francisco 96519

Yokosuka
Kenwood Rep.; c/o
A-33, Yokosuka NEX No. 260-010
FPO Seattle 98760

Atsugi
Kenwood Rep.; c/o
Atsugi NEX No. 260-020 FPO Seattle 98767

Iwakuni
Kenwood Rep.; c/o
Marine Corps Exchange, Marine Corps Air Station,
FPO Seattle 98764

Sasebo
Sasebo NEX;
Navy Exchange 260-040
F.A. Box 115 FPO Seattle 98766

Okinawa
Kenwood Rep.; c/o
OWA, AAFES-PAC, APO San Francisco 96230

KOREA:
Kenwood Rep.; c/o
KOAX Repair Shop, AAFES-PAC
DD-Camp Market, APO San Francisco 96488

GUAM:
Kenwood Rep.; c/o
Guam NEX No. 230-010,
FPO San Francisco 96630
Kenwood Rep.; c/o
GUAX, AAFES-PAC, APO San Francisco 96334

U.S.A.:

Hawaii
Kenwood Factory Service
99-394 Iwaeana St., Aiea, Hawaii 96701

Alaska
Vista Radio TV;
861 East Loop Road, Anchorage, Alaska 99501
Anchorage Commercial Electronics, Inc.;
1450 East 9th Ave., Anchorage, Alaska 99501

In The Continental U.S.A.
For Nearest Authorized Service Center;
Tel: 1-800-536-9663

Kenwood Service U.S.A.
Kenwood Factory Service;
P.O. Box 22745, 2201 East Dominguez Street,
Long Beach, California 90801-5745
Tel: (310) 639-5300

EUROPE:
Please inquire at the military resale outlets where you bought your Kenwood products, or KENWOOD ELECTRONICS DEUTSCHLAND GmbH; Rembrücker-Str. 15, 63150 Heusenstamm, Germany; Tel: 49-06104-69010

CANADA KENWOOD ELECTRONICS CANADA INC.

KENWOOD WARRANTY

KENWOOD ELECTRONICS CANADA INC. (hereinafter called "KENWOOD"), gives the following written warranty to the original customer of each new Kenwood product distributed in Canada by KENWOOD and purchased from a dealer authorized by KENWOOD.

KENWOOD warrants that each new Kenwood product, under normal use, is free from any defects, subject to the terms and conditions set forth below. If a defect should occur within the warranty period, repairs will be made free of charge for parts and labour when such defects are determined by KENWOOD or its authorized service centres to be attributable to faulty materials or workmanship at time of manufacture. Please contact KENWOOD to confirm if a dealer or service centre is authorized by KENWOOD.

WARRANTY PERIOD
This Kenwood product is warranted for parts and labour for a period of one (1) year from the date of original purchase, lease or rental, except for products which are used in a professional or commercial application, which are warranted for a period of ninety (90) days for parts and labour and are subject to the terms and conditions of the warranty.

WARRANTY EXCLUSIONS
This warranty excludes:

- Products purchased in a foreign country or purchased in Canada and taken to a foreign country.
- Products purchased from a dealer not authorized by KENWOOD.
- Products with the serial number defaced, altered or missing.
- Periodic check-ups which do not disclose any defects covered by this warranty.
- Defects resulting from disaster, accident, abuse, misuse, lightning, power surges, neglect or lack of periodic maintenance, unauthorized modification or failure to follow instructions in the owner's manual.
- Defects or damage as a result of repairs performed by a person or party not authorized by KENWOOD.
- Defects resulting from the use of parts or devices that do not conform to KENWOOD specifications.
- Damage or deterioration occurring to any exterior finishes, cosmetic parts, tape heads, adaptors, antennas, cables, tapes, discs or faults or damage caused by defective or leaking batteries.
- Defects or damage occurring during shipping (claims should be presented to the shipping company).
- Product voltage and/or line frequency conversions.
- Product installation or removal charges.

TO OBTAIN WARRANTY SERVICE
Should your Kenwood product require warranty service, deliver it to any authorized KENWOOD service centre and present the original copy of your bill of sale and this warranty card as proof of warranty, or send your product fully insured and freight prepaid to the nearest authorized KENWOOD service centre. To avoid possible shipping damage, make sure the product is properly packed. Include a copy of your original bill of sale and this warranty card as proof of warranty along with your name, home and/or work telephone number(s), a complete return address and a detailed description of the fault(s). Products repaired within warranty will be returned freight prepaid to destinations within Canada. The customer is responsible for all freight and related costs for the return of product(s) to destinations outside Canada.

ENTIRE WARRANTY
This warranty constitutes the entire written warranty given by KENWOOD. No person, party, dealer or service centre or their agents or employees are authorized to extend or enlarge this warranty on behalf of KENWOOD by any written or verbal statement or advertisement or promotion, including any extended warranty program or plan that may be offered by the dealer or service centre, unless approved in writing by KENWOOD.

DISCLAIMER
KENWOOD disclaims any responsibility for loss of time or use of the product or any other indirect, incidental or consequential damage to other products or goods, inconvenience or commercial loss.

NOTICE TO CONSUMER
The provisions contained in this written warranty are not intended to limit, modify, take away, disclaim or exclude any warranties or rights you may have which are set forth in any applicable provincial or federal laws or legislation.

IMPORTANT
This warranty card by itself is not considered by KENWOOD as a valid proof of purchase. When applying for warranty repairs, you must present the original copy of your bill of sale and this warranty card as proof of warranty, so we recommend that they be kept in a safe place, should they be required in the future.

KENWOOD ELECTRONICS CANADA INC.
6070 Kestrel Road, Mississauga, Ontario, Canada L5T 1S8
Tel.: (905) 670-7211
Fax: (905) 670-7248

ATTENTION
This card and receipt (or invoice) are necessary to purchase a new panel in case of theft or damage.

GARANTIE KENWOOD

KENWOOD ELECTRONICS CANADA INC. (ci-après appelée "KENWOOD"), donne par écrit la garantie suivante à l'acheteur original de chaque nouveau produit Kenwood distribué au Canada par KENWOOD et acheté à un concessionnaire autorisé par KENWOOD.

KENWOOD garantit, sous réserve des termes et des conditions énoncés ci-dessous, que chaque nouveau produit Kenwood, dans des conditions d'emploi normales, est exempt de tous défauts. Si l'un défaut se produit pendant la période de garantie, KENWOOD s'engage à assumer le coût des pièces défectueuses et de la main-d'oeuvre nécessaires pour effectuer les réparations pourvu que de tels défauts sont attribuables à des pièces défectueuses employées lors de la fabrication du produit Kenwood ou à la main-d'oeuvre tel qu'établi par KENWOOD ou par l'un de ses centres de service autorisés. Appelez KENWOOD pour vérifier si un concessionnaire ou un centre de service est autorisé par KENWOOD.

PÉRIODE DE GARANTIE
Les pièces et la main-d'oeuvre nécessaires pour la réparation des produits Kenwood sont garanties pendant la période d'un (1) an à compter de la date d'achat, de bail ou de location originale, sauf dans les cas où les produits Kenwood sont employés dans un but professionnel ou commercial, où la garantie des pièces et de la main-d'oeuvre demeure en vigueur pendant une période de quatre-vingt-dix (90) jours sous réserve des termes et des conditions de la garantie.

EXCLUSIONS DE GARANTIE
Cette garantie ne couvre pas:

- les produits achetés à l'étranger ou achetés au Canada et transportés à l'étranger;
- les produits achetés à un concessionnaire non autorisé par KENWOOD;
- les produits dont le numéro de série manque, a été effacé ou modifié;
- les services d'entretien périodiques qui n'incluent aucun défaut couvert par cette garantie;
- les défauts causés par les désastres, les accidents, les abus, les emplois incorrects, les éclairs, les surtensions de courant, les manques de soins ou d'entretiens périodiques, les modifications non autorisées ou les manques de respect du mode d'emploi;
- les défauts ou les dommages causés lors de réparations effectuées par une personne ou par une partie non autorisée par KENWOOD;
- les défauts causés par l'emploi de pièces ou de dispositifs qui ne se conforment pas aux exigences de KENWOOD;
- les finitions extérieures, les pièces cosmétiques, les têtes de bandes, les adaptateurs, les antennes, les câbles, les bandes, les disques endommagés ou déparés, ni les défauts ou dommages causés par des piles défectueuses ou qui fuient;
- les défauts ou dommages qui se produisent pendant l'expédition des produits Kenwood (On devrait déposer de telles réclamations auprès des compagnies de transport);
- les conversions de tension et/ou de fréquence du produit;
- les frais d'installation ou d'enlèvement du produit.

COMMENT OBTENIR DU SERVICE SOUS GARANTIE
Au cas où un service sous garantie de votre produit Kenwood s'avère nécessaire, veuillez livrer le produit à n'importe quel centre de service KENWOOD et présenter la copie originale du contrat de vente et cette carte de garantie en tant que preuve de garantie ou veuillez faire parvenir votre produit assuré et port payé au centre de service KENWOOD autorisé le plus proche. Pour éviter toutes possibilités de dommages pendant le transport, veuillez bien emballer le produit. Veuillez inclure une copie du contrat de vente original et cette carte de garantie en tant que preuve de garantie aussi bien que votre nom, numéros de téléphone au poste de travail et/ou au domicile, votre adresse et une description détaillée des défauts. Les produits sous garantie réparés seront retournés port payé aux destinations à l'intérieur du Canada. Le consommateur sera responsable de tous frais de transport et d'autres frais qui s'y rapportent pour faire expédier les produits à destinations à l'extérieur du Canada.

L'ENTIERE GARANTIE
Cette garantie représente l'entière garantie donnée par écrit par KENWOOD. KENWOOD ne se tient aucunement responsable de toutes extensions ni de toutes augmentations de cette garantie faites ou entreprises par toutes personnes, parties, concessionnaires ou centres de service ou par leurs agents ou employés au nom de KENWOOD au moyen d'affirmations verbales ou écrites, d'annonces ou de promotions, y inclut tous programmes ou plans de garantie étendue que puissent offrir les concessionnaires ou les centres de service, à moins que KENWOOD n'y ait consenti par écrit d'avance.

RENONCIATION
KENWOOD renonce à toutes responsabilités de perte de temps, d'emploi du produit, de tous dommages indirects ou accessoires causés à d'autres produits ou biens, de tous inconvénients ou de toutes pertes commerciales.

AVIS AUX CONSOMMATEURS
Les stipulations contenues dans la présente garantie écrite n'ont pas pour but de limiter, de modifier, de diminuer, de rejeter ni d'exclure d'autres garanties ni droits énoncés dans n'importe quelles lois ou législations provinciales ou fédérales.

IMPORTANT
KENWOOD ne considère pas cette garantie toute seule comme étant une preuve d'achat valide. Lorsqu'on demande du service sous garantie, il faudra présenter la copie originale du contrat de vente aussi bien que cette carte de garantie en tant que preuve de garantie. On recommande de les conserver dans un lieu sûr au cas où elles s'avèreraient nécessaires à l'avenir.

KENWOOD ELECTRONICS CANADA INC.
6070 Kestrel Road, Mississauga, Ontario, Canada L5T 1S8
Téléphone: (905) 670-7211
Télécopieur: (905) 670-7248

ATTENTION
La carte de garantie et la preuve d'achat (ou la facture) sont nécessaires à l'achat d'une nouvelle façade détachable en cas de dommages ou de vol.